



PE326TSC-50-4

GENERAL PURPOSE ELECTRIC MOTOR

NEMA PREMIUM EFFICIENCY

TOTALLY ENCLOSED FAN COOLED - C-FLANGE WITH FEET

INVERTER DUTY 10:1 CT; 20:1 VT - NEMA MG1 PART 31

Factory Certified for T2B Class I, Division II, Groups A,B,C & D and Class II, Division II, Groups F & G

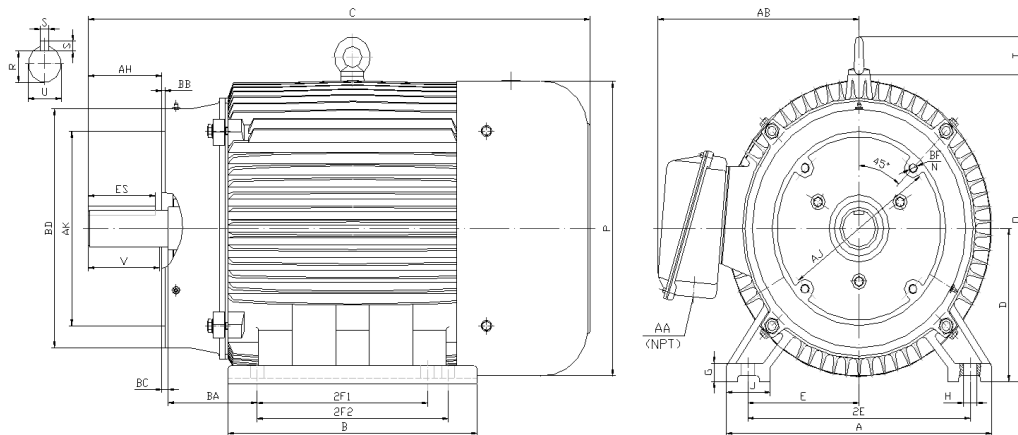

DIMENSIONS

HP	RPM	Frame	MOUNTING														
			A	B	C	D	G	H	J	E	2E	2F1	2F2	O	P	T	BA
50	1800	326TSC	15.5	14.7	29.8	8	1	0.66	2.75	6.25	12.5	10.5	12	15.9	15.7	2.6	5.25

FLANGE							Shaft Extension, Key Set					
AH	AJ	AK	BB	BC	BD	BF	U	V	R	S	ES	N-W
3.5	11	12.5	0.25	0.25	14	4*5/8-11	1.875	3.5	1.591	0.5	2.03	NA

Conduit Box		Bearings		Mount
AA	AB	DE	ODE	
2	12.3	6312	6312	F1

BEARING LUBRICATION: The bearings come lubricated with Mobil Polyrex EM Polyurea Grease. It is recommended that you add some additional lubrication when the motor is installed.

Three options (brands) for suitable lubrication include, but are not limited to, the following:

- 1.) Mobil Polyrex EM
- 2.) Citco Polyurea MP
- 3.) Conoco Phillips Polytac EP





PE326TSC-50-4

GENERAL PURPOSE ELECTRIC MOTOR

NEMA PREMIUM EFFICIENCY

TOTALLY ENCLOSED FAN COOLED - C-FLANGE WITH FEET

INVERTER DUTY 10:1 CT; 20:1 VT - NEMA MG1 PART 31

Factory Certified for T2B Class I, Division II, Groups A,B,C & D and Class II, Division II, Groups F & G

PERFORMANCE DATA

HP	RPM	Frame	Voltage	Frequency (Hz)	Full Load S.F.	Insulation Class	NEMA Design	Slip (%)	NEMA Code	Enclosure Type	IP Rating	Max. Ambient
50	1780	326TSC	230/460	60	1.15	F	B	1.1	G	TEFC	55	40 °C

Amps (460V)		Efficiency (%)			Power Factor			Torque (ft-lb)			DE Bearing	ODE Bearing	Connection	Weight (lbs.)
FLA	LRA	100%	75%	50%	100%	75%	50%	FLT	LRT %	BDT %				
58.3	362	94.5	94.5	94.6	0.83	0.79	0.70	148.4	160	255	6312	6312	12 Lead 2Δ/Δ	626

*Usable at 208 Volts

NAME PLATE

		AC INDUCTION MOTOR INVERTER DUTY 20:1 VT; 10:1 CT						CONNECTION DIAGRAMS		
CAT NO. PE326TSC-50-4		FRAME 326TSC		PHASE 3		230V 				
HZ 60	S.F. 1.15	HZ 50	S.F. 1.0	ENCL TEFC	IP 55					
HP 50	RPM 1780	HP 50	RPM 1475	DUTY CONT	DES B					
VOLTS 230/460		VOLTS 190/380		AMB 40 °C	INS F					
AMPS 116.6 / 58.3		AMPS 143/71.5		DE BRG 6312						
CODE G	P.F. 0.83	CODE F	P.F. 0.85	ODE BRG 6312						
EFF 94.5	MIN 93.6	EFF 93.0	MIN 91.8	LUB: Mobil Polyrex EM						
MOTOR WEIGHT 626	LBS	CONNECTION 12 Lead 2Δ/Δ		SER NO		460V 				
General purpose use on industrial machinery installed in damp, dusty or dirty environments. Hernando, Mississippi								CC082A		

APPLICATIONS:

General purpose use on pumps, fans, blowers, compressors, conveyors, material handling and other industrial machinery installed in damp, dusty or dirty environments.