



## PE405TC-100-4

GENERAL PURPOSE ELECTRIC MOTOR

NEMA PREMIUM EFFICIENCY

TOTALLY ENCLOSED FAN COOLED - C-FLANGE WITH FEET

INVERTER DUTY 10:1 CT; 20:1 VT - NEMA MG1 PART 31

Factory Certified for T2B Class I, Division II, Groups A,B,C & D and Class II, Division II, Groups F & G

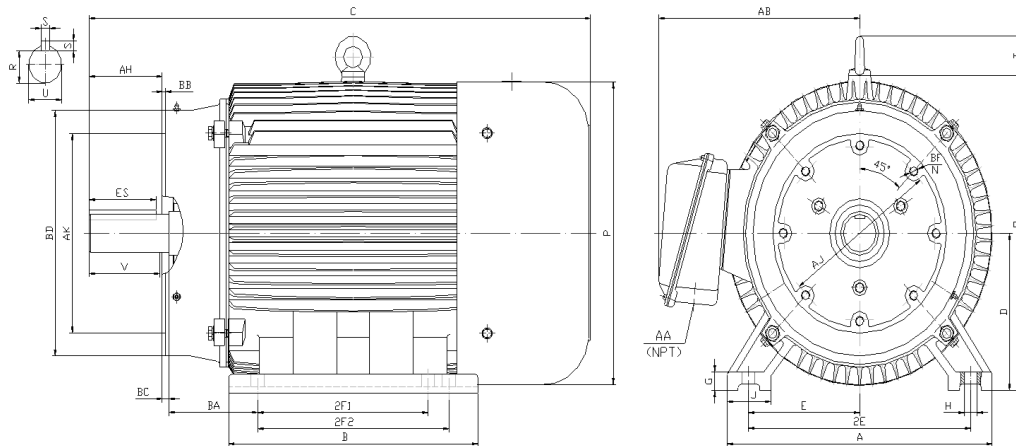

### DIMENSIONS

HP	RPM	Frame	MOUNTING														
			A	B	C	D	G	H	J	E	2E	2F1	2F2	O	P	T	BA
100	1800	405TC	19.3	17.9	38	10	1.18	0.81	3.15	8	16	12.25	13.75	21.1	21.6	2.6	6.62

FLANGE							Shaft Extension, Key Set					
AH	AJ	AK	BB	BC	BD	BF	U	V	R	S	ES	N-W
7	11	12.5	0.25	0.25	15.5	8*5/8-11	2.875	7	2.45	0.75	5.65	NA

Conduit Box		Bearings		Mount
AA	AB	DE	ODE	
3	16.6	6318	6314	F1

**BEARING LUBRICATION:** The bearings come lubricated with Mobil Polyrex EM Polyurea Grease. It is recommended that you add some additional lubrication when the motor is installed.

Three options (brands) for suitable lubrication include, but are not limited to, the following:

- 1.) Mobil Polyrex EM
- 2.) Citco Polyurea MP
- 3.) Conoco Phillips Polytac EP





## PE405TC-100-4

GENERAL PURPOSE ELECTRIC MOTOR

NEMA PREMIUM EFFICIENCY

TOTALLY ENCLOSED FAN COOLED - C-FLANGE WITH FEET

INVERTER DUTY 10:1 CT; 20:1 VT - NEMA MG1 PART 31

Factory Certified for T2B Class I, Division II, Groups A,B,C & D and Class II, Division II, Groups F & G

### PERFORMANCE DATA

HP	RPM	Frame	Voltage	Frequency (Hz)	Full Load S.F.	Insulation Class	NEMA Design	Slip (%)	NEMA Code	Enclosure Type	IP Rating	Max. Ambient
100	1790	405TC	230/460	60	1.15	F	B	0.6	G	TEFC	55	40 °C

Amps (460V)		Efficiency (%)			Power Factor			Torque (ft-lb)			DE Bearing	ODE Bearing	Connection	Weight (lbs.)
FLA	LRA	100%	75%	50%	100%	75%	50%	FLT	LRT %	BDT %				
112	725	95.4	95.4	95.2	0.87	0.84	0.77	295.17	155	240	6318	6314	12 Lead 2Δ/Δ	1228

\*Usable at 208 Volts

### NAME PLATE

		AC INDUCTION MOTOR INVERTER DUTY 20:1 VT; 10:1 CT						CONNECTION DIAGRAMS		
CAT NO. PE405TC-100-4		FRAME 405TC		PHASE 3		230V 				
HZ 60	S.F. 1.15	HZ 50	S.F. 1.0	ENCL TEFC	IP 55					
HP 100	RPM 1790	HP 100	RPM 1485	DUTY CONT	DES B					
VOLTS 230/460		VOLTS 190/380		AMB 40 °C	INS F					
AMPS 224 / 112		AMPS 274/137		DE BRG 6318						
CODE G	P.F. 0.87	CODE F	P.F. 0.88	ODE BRG 6314						
EFF 95.4	MIN 94.5	EFF 94.1	MIN 93.2	LUB: Mobil Polyrex EM						
MOTOR WEIGHT 1228	LBS	CONNECTION 12 Lead 2Δ/Δ		SER NO		460V 				
General purpose use on industrial machinery installed in damp, dusty or dirty environments. Hernando, Mississippi								CC082A		

### APPLICATIONS:

General purpose use on pumps, fans, blowers, compressors, conveyors, material handling and other industrial machinery installed in damp, dusty or dirty environments.